

# baridi

## 4-in-1 Portable Air Conditioning Unit with Window Sealing Kit - White



### Model No. DH412

Thank you for purchasing a Dellonda product. Manufactured to a high standard, this product will, if used according to these instructions, and properly maintained, give you years of trouble free performance.

## Important Information

Please read these instructions carefully. Note the safe operational requirements, warnings & cautions. Use the product correctly and with care for the purpose for which it is intended. Failure to do so may cause damage and/or personal injury and will invalidate the warranty. Keep these instructions safe for future use.



Refer to instruction



Do not cover



Indoor use only



Caution:  
Risk of fire

**This unit uses a flammable refrigerant.**

**If refrigerant leaks and comes in contact with fire or heating part, it will create harmful gas and there is risk of fire.**

**Read the USER MANUAL carefully before operation.**

Install the unit in rooms which exceed 6m<sup>2</sup>.

## Specification

Model:	DH412
Rated Capacity:	1470W
IP Rating:	IPX1
Noise Level:	65dB(A)
Cooling Capacity:	5000Btu/hr
Discharge Side Pressure:	3.2Mpa
Energy Class:	A
Exhaust Hose Length:	650mm
Fuse Rating:	13A
Mass:	R290 105g
Maximum Airflow:	290m <sup>3</sup> /hr
Maximum Water Extraction Rate:	11L/day
Weight:	18.5kg
Plug Type:	3-Pin
Power Supply Cable Length:	1.8m
Power:	560W
Refrigerant:	R290
Suction Side Pressure:	0.7Mpa
Supply:	230V ~ 50Hz

## Safety Instructions

### • ELECTRICAL SAFETY

- **WARNING!** It is the user's responsibility to check the following:
  - Check all electrical equipment and appliances to ensure that they are safe before using.
  - Inspect power supply leads, plugs and all electrical connections for wear and damage.
  - Ensure that the insulation on all cables and on the appliance is safe before connecting it to the power supply.
  - **DO NOT** use worn or damaged cables, plugs or connectors.
  - Ensure that any faulty item is repaired or replaced immediately by a Baridi qualified technician.
  - If the cable or plug is damaged during use, switch off the electricity supply and remove from use.
  - Baridi recommend that an **RCD** (Residual Current Device) is used with all electrical products.
  - **Important:** Ensure that the voltage rating on the appliance suits the mains power supply.
  - **DO NOT** pull or carry the appliance by the power cable.
  - **DO NOT** pull the plug from the socket by the cable. **DO NOT** use an extension cord or an adapter plug.
  - If the supply cord is damaged, it must be replaced by the manufacturer, its service agent or similarly qualified persons in order to avoid a hazard.
- **CAUTION:** In order to avoid a hazard due to inadvertent resetting of the thermal cut-out, this appliance must not be supplied through an external switching device, such a timer, or connected to a circuit that is regularly switched on and off by the utility.

### • GENERAL SAFETY

- Children from age 8 years and above, persons with reduced physical, sensory, or mental capabilities those with lack of experience and knowledge can use the appliance, if they have been given supervision or instruction concerning use of the appliance in a safe way to understand the hazards involved.
- Children shall **NOT** play with the appliance.
- Cleaning and user maintenance on the appliance shall not be made by children without supervision.
- The appliance shall be disconnected from its power source during service and when replacing parts.
- The unit is designed only for use with R-290(propane) gas as the designated refrigerant.

- The refrigerant loop is sealed. Only a qualified technician should attempt to service or repair.
- Propane gas collects first in low areas but can be circulated by the fans.
- If propane gas is present or even suspected, do not allow untrained personnel to attempt to find the cause.
- The propane gas used in the unit has no odour. The lack of smell does not indicate a lack of escaped gas.
- If a leak is detected, immediately evacuate all persons from the area, ventilate the room and contact the local fire department to advise them that a propane leak has occurred.
- **DO NOT** let any persons back into the room until the qualified service technician has arrived and that technician advises that it is safe to return to the room.
- No open flames, cigarettes or other possible sources of ignition should be used inside or in the vicinity of the units.
- Component parts are designed for propane and non-incentive and non-sparking. Component parts shall only be replaced with identical repair parts.
- **FAILURE TO ABIDE BY THIS WARNING COULD RESULT IN AN EXPLOSION, DEATH, INJURY AND PROPERTY DAMAGE.**
- Unplug the power cord when cleaning or when not in use.
- **DO NOT** operate with wet hands. Prevent water from spilling onto the unit.
- **DO NOT** immerse or expose the unit to rain, moisture or any other liquid.
- **DO NOT** leave the unit running unattended. **DO NOT** tilt or turn over the unit.
- **DO NOT** put objects on the unit. **DO NOT** climb or sit on the unit.
- **DO NOT** insert fingers or other objects into the air outlet.
- **DO NOT** touch the air inlet or the aluminium fins of the unit.
- **DO NOT** operate the unit if it is dropped, damaged or showing signs of product malfunction.
- **DO NOT** clean the appliance with any chemicals.
- Ensure the unit is far away from fire, inflammable, or explosive objects.
- **DO NOT** use means to accelerate the defrosting process or to clean, other than those recommended by the manufacture.
- The appliance shall be stored in a room without continuously operation devices (for example: open flames, an operating gas appliance or an operating electric heater).
- The appliance shall be stored so as to prevent mechanical damage from occurring.
- **DO NOT** piece or burn, even after end of life.
- Be aware that refrigerants may not contain an odour.
- Pipe-work shall be protected from physical damage and shall not be installed in an unventilated space, if that space is smaller than 9m<sup>2</sup>.
- Keep any required ventilation openings clear of obstruction.
- The appliance shall be stored in a well-ventilated area where the room size corresponds to the room area as specified for operation.
- **DO NOT** unplug while the unit is operating.
- **FLAMMABLE REFRIGERANTS USED**
- **Checks to the area**
- Prior to beginning work, safety checks are necessary to ensure that the risk of ignition is minimised.
- **Work procedure**
- Work shall be undertaken under a controlled procedure so as to minimise the risk of a flammable gas or vapour being present while the work is being performed.
- **General work area**
- All maintenance staff and others working in the local area shall be instructed on the nature of work being introduction carried out. Work in confined spaces shall be avoided.
- **Checking for presence of refrigerant**
- The area shall be checked with an appropriate refrigerant detector prior to and during work, to ensure the technician is aware of potentially toxic or flammable atmospheres. Ensure that the leak detection equipment being used is suitable for use with all applicable refrigerants, i.e. non-sparking, adequately sealed or intrinsically safe.
- **Presence of fire extinguisher**
- Have a dry powder or CO<sub>2</sub> fire extinguisher adjacent to the charging area.
- **No ignition sources**
- All possible ignition sources, including cigarette smoking, should be kept sufficiently far away from the site of installation, repairing, removing and disposal, during which refrigerant can possibly be released to the surrounding space. Prior to work taking place, the area around the equipment is to be surveyed to make sure that there are no flammable hazards or ignition risks.
- **Ventilated area**
- Ensure that the area is adequately ventilated before breaking into the system or conducting any hot work. A degree of ventilation shall continue during the period that the work is carried out. The ventilation should safely disperse any released refrigerant and preferably expel it externally into the atmosphere.
- **Checks to the refrigerating equipment**
- At all times, the manufacturer's maintenance and service guidelines shall be followed. If in doubt, consult the manufacturer's technical department for assistance. The following checks shall be applied to installations using flammable refrigerants: The actual refrigerant charge is in accordance with the room size within which the refrigerant containing parts are installed. The ventilation machinery and outlets are operating adequately and are not obstructed. Marking to the equipment continues to be visible and legible. Markings and signs that are illegible shall be corrected. Refrigerating pipe or components are installed in a position where they are unlikely to be exposed to any substance which may corrode refrigerant containing components, unless the components are constructed of materials which are inherently resistant to being corroded or are suitably protected against being so corroded.
- **Checks to electrical devices**
- Repair and maintenance to electrical components shall include initial safety checks and component inspection procedures. If a fault exists that could compromise safety, then no electrical supply shall be connected to the circuit until it is satisfactorily dealt with. If the fault cannot be corrected immediately but it is necessary to continue operation, an adequate temporary solution shall be used.
- Initial safety checks shall include that: Capacitors are discharged: this shall be done in a safe manner to avoid possibility of sparking. No live electrical components and wiring are exposed while charging, recovering or purging the system. There is continuity of earth bonding.
- **Cabling**
- Check that cabling will not be subject to wear, corrosion, excessive pressure, vibration, sharp edges or any other adverse environmental effects.
- **Detection of flammable refrigerants**
- Under no circumstances shall potential sources of ignition be used in the searching for or detection of refrigerant leaks. A halide torch (or any other detector using a naked flame) shall not be used.
- **Removal and evacuation**

- When breaking into the refrigerant circuit to make repairs – or for any other purpose – conventional procedures shall be used. However, for flammable refrigerants it is important that best practice is followed since flammability is a consideration. The following procedure shall be adhered to: Remove refrigerant; Purge the circuit with inert gas; Evacuate; Purge with inert gas; Open the circuit by cutting or brazing.
- The refrigerant charge shall be recovered into the correct recovery cylinders. The system shall be purged with oxygen-free nitrogen to render the appliance safe for flammable refrigerants. This process may need to be repeated several times. Compressed air or oxygen shall not be used for purging refrigerant systems.
- Purging shall be achieved by breaking the vacuum in the system with oxygen-free nitrogen and continuing to fill until the working pressure is achieved, then venting to atmosphere, and finally pulling down to a vacuum. This process shall be repeated until no refrigerant is within the system. When the final oxygen-free nitrogen charge is used, the system shall be vented down to atmospheric pressure to enable work to take place. This operation is absolutely vital if brazing operations on the pipe-work are to take place.
- Ensure that the outlet for the vacuum pump is not close to any potential ignition sources and that ventilation is available.
- **Charging procedures** In addition to conventional charging procedures, the following requirements shall be followed. Ensure that contamination of different refrigerants does not occur when using charging equipment. Hoses or lines shall be as short as possible to minimise the amount of refrigerant contained in them. Cylinders shall be kept in an appropriate position according to the instructions. Ensure that the refrigerating system is earthed prior to charging the system with refrigerant. Label the system when charging is complete (if not already). Extreme care shall be taken not to overfill the refrigerating system.
- Prior to recharging the system, it shall be pressure-tested with the appropriate purging gas. The system shall be leak-tested on completion of charging but prior to commissioning. A follow up leak test shall be carried out prior to leaving the site.

## Contents

1. Exhaust hose
2. Hose connector
3. Window kit adaptor
4. Remote control
5. Drainage pipe
6. Window kit

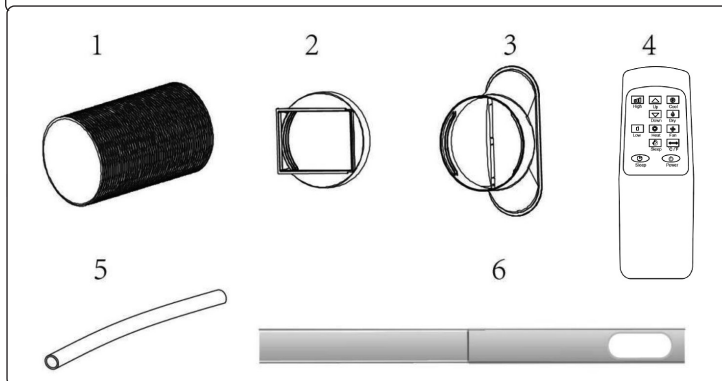
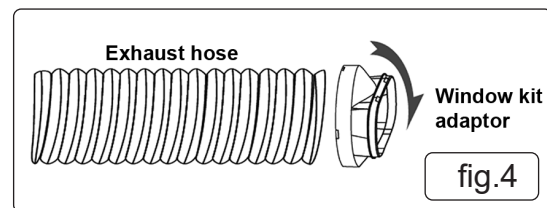
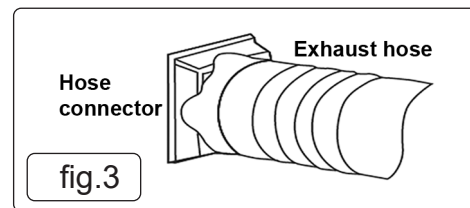
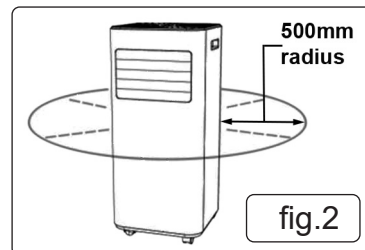
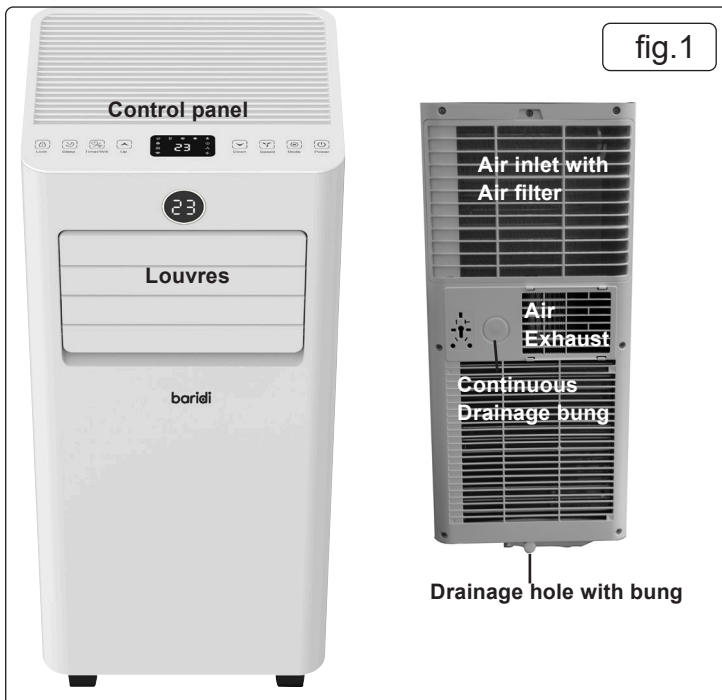

- Unpack the product and check contents. Should there be any damaged or missing parts contact your supplier immediately.
- **LOCATION**
- Place the appliance on a firm, level surface.
- Ensure that there is a clear area of at least 500mm around the appliance (fig.2) to allow for adequate air circulation.
- **DO NOT** operate the appliance in close proximity to walls, curtains or other objects that may block the air inlet or outlet.
- **WARNING! DO NOT** locate the appliance where it is subject to:
- Heat sources such as radiators, ovens or similar

- Direct sunlight
- Mechanical vibration or shock
- Excessive dust
- Lack of ventilation i.e., inside a cabinet or bookcase
- Uneven surfaces
- **ASSEMBLE THE EXHAUST HOSE**
- **WARNING!** The air conditioning unit must be vented to outside. This ensures that any heat and moisture is removed from the designated room space.
- **WARNING!** Install the unit in rooms which exceed 6m<sup>2</sup>.
- Screw fit the hose connector to one end of the exhaust hose (fig.3).
- Screw fit the window kit adapter to the other end of the exhaust hose (fig.4).

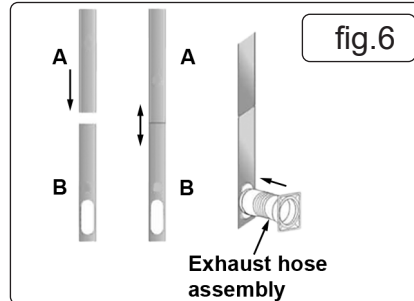
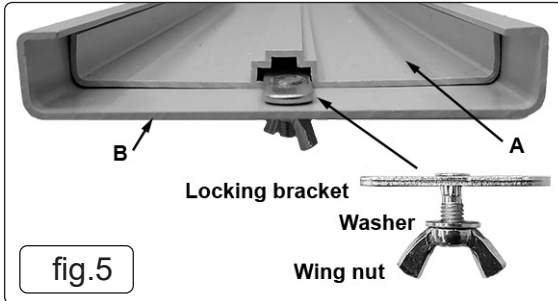

- Locate window kit locking bracket's threaded shaft through hole in window kit part B (fig.5).
- Attach washer and wing nut to threaded shaft (fig.5).
- Slide window kit part A into part B (fig 6) and locate locking bracket plate into central slot on part A (fig.5).
- Extend the adjustable window kit to suit the size of the window and tighten the wing nut (fig.5) to lock.
- Attach exhaust hose assembly, see section 5.2, to window kit part B (fig.6).
- **ATTACH WINDOW KIT ASSEMBLY (SEE ALSO THE SECTION AT END OF MANUAL FOR ALTERNATIVE WINDOW KIT INCLUDED).**

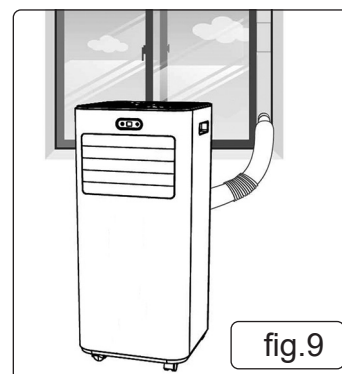
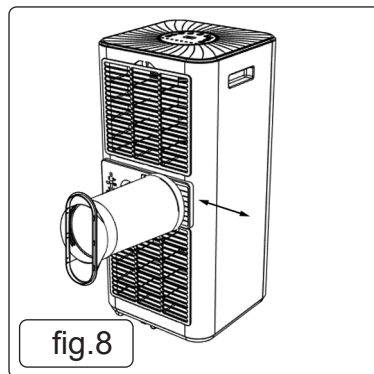
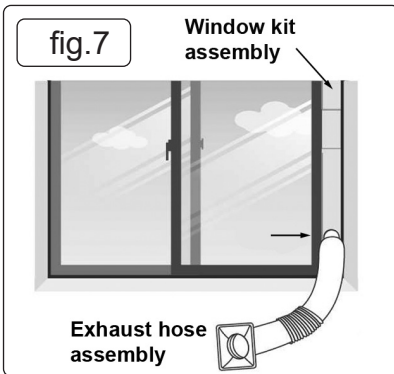

- Open the window and place the window kit into position, then close the window onto the window kit (fig.7).
- **NOTE:** To obtain maximum efficiency it is recommended that any gaps between the window kit and the sides of the window are sealed.
- Attach the hose connector on the hose assembly to the exhaust outlet (fig.1 #7) by sliding the it horizontally into position (fig.8).
- Place the appliance near to a suitable electrical power outlet and adjust the flexible exhaust hose to suit, avoiding any sharp bends to the hose (fig.9).
- Adjust the louvre panel (fig.1 #2) to suit (fig.9).

## Operation

### CONTROL PANEL AND DISPLAY

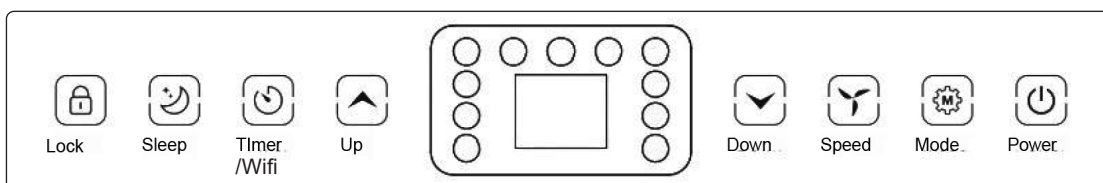

- **POWER:** Turn On or Off
- **MODE:** Switch between modes
- **SPEED:** Switch between High and Low
- **TIMER:** Sets time to automatically turn on or off
- Long press this button to start the network configuration or disconnect the **WIFI**
- **SLEEP:** Press the Sleep button on remote control to start sleep function
- **UP:** Increase temperature or Timer setting
- **DOWN:** Decrease temperature or Timer setting
- **LOCK:** Long press this button for 3-5 seconds to start child-lock function

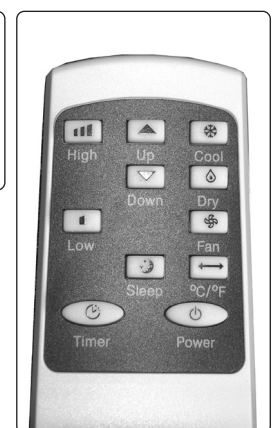

- **SETTINGS**
- **START UP AND SHUTDOWN**
- Press **POWER** to turn on

- Press **MODE** to select desired mode
- Press **POWER** again to turn off

- **OPERATIONAL MODES**

- **The unit has four modes: FAN, COOL, DEHUMIDIFIER, SLEEP**

- **A. COOLING YOUR ROOM**

- Select the cool mode to lower the temperature in your room.
- Press **MODE** button repeatedly until the **COOL** indicator lights up.
- Press Up/Down button to adjust the temperature which is displayed on the screen.
- Press **SPEED** button repeatedly until the desired fan speed indicator lights up.
- To control the direction of the air flow horizontally, please adjust the inner louvres by hand.
- **NOTE: The air conditioner stops if the room temperature is lower than selected temperature.**

- **B. VENTILATING YOUR ROOM**

- Press **MODE** button repeatedly until the **FAN LED** indicator lights up.
- In ventilation mode the room air is circulated, but not cooled.
- Press **SPEED** button repeatedly to select the fan speed as desired.

- **C. DRYING YOUR ROOM**

- Press **MODE** button on the control panel or remote control, until the dry **LED** indicator lights up. The fan speed is not selectable. Connect the hose to the drain outlet at the bottom of the unit.
- **NOTE:** In this mode, the fan speed switches over to low speed and cannot be adjusted.

- **D. SLEEP MODE**

- The sleep mode can be activated when in cool mode.
- After 1 hour the preset temperature is increased by 1°C, after another hour the preset temperature will again be increased by 1°C. After two hours the set temperature will not change again. Indicator **LEDs** dim in sleep mode.
- The temperature is kept constant for 10 hours. All the indicators dim to dark. The fan speed may switch over to low speed for silent operating and cannot be adjusted.

- **TIMER SETTING (1-24 hours)**

- Timer has two ways of working:

- |                                  |   |      |   |
|----------------------------------|---|------|---|
| • To turn on (when power is on)  | Press <b>TIMER</b> button to turn on the timer function | then | Press <b>UP/DOWN</b> repeatedly to set the delay OFF time |
| • To turn on (when power is off) | Press <b>TIMER</b> button to turn on the timer function | then | Press <b>UP/DOWN</b> repeatedly to set the delay ON time  |

- **CANCEL TIMER:**

- Press the **UP** or **DOWN** button repeatedly until the **LED** displays '00'.
- **NOTE:** when **POWER** is pressed unit will also exit the timer setting.
- Long press **TIMER** button to start wifi function, please refer to wifi instruction at the end of the manual.

- **AUTOMATIC DEFROST**

- At low room temperatures, frost may build up on the evaporator during operation. The unit will automatically start defrosting and the **POWER LED** will blink. The defrost control sequence is as follows:
- A: When the unit operates in the cooling mode and drying mode, the ambient temperature sensor senses the evaporator coil temperature is below -1°C. The compressor will stop operating for 10 minutes until the coil temperature is up to 7°C. The unit will restart in cooling mode.
- B: When the unit operates in the drying operation mode, once the coil temperature sensor senses the temperature of the evaporator is below 40°C and the differential temperature between coil temperature and room temperature is below 19°C and after compressor operation for 20minutes, the unit will start defrosting for 5 minutes and the power indicator will blink.

- **OVERLOAD PROTECTION:** In the event of a power loss, to protect the compressor there is a 3-minute delay until the compressor restarts.

- **DRAINAGE**

- **MANUAL DRAINAGE**

- When the machine stops because the water pan is full, remove from mains supply.
- **NOTE:** Move the machine carefully, so as not to spill the water in the water pan at the bottom of the unit.
- Place a water container below the water outlet at the rear.
- Unplug the water drainage bung, fig.1, the water will drain.
- **NOTE:**
- Make sure water drainage bung is properly inserted.
- During drainage, the body can be tilted slightly backwards.
- If the water container cannot hold all the water, before the water container is full, replace the bung to prevent water from flowing to the floor or the carpet.
- When the water is discharged, reinsert the water plug.
- Restart the machine after the water bung and drainage cover are reinstalled.

- **CONTINUOUS DRAINAGE**

- The self-evaporating system uses the collected water to cool the condenser coils for better performance.
- There is no need to empty the drainage tank in cooling operation except in drying operation and high humidity conditions.
- The condensate water evaporates at the condenser and evacuated through the exhaust hose.

- For continuous operation or unattended operating in drying operation, connect the attached drain hose to the unit. Condensate water can be automatically flowed into a bucket or drain by gravity.
- Switch off the unit before operating.
- Remove the drainage bung of the water outlet opening, and keep it safe.
- Fit drain hose securely, make sure it is not kinked and clear of obstruction.
- Place the outlet of hose over a drain or bucket and ensure that water could freely flow out of the unit.
- **DO NOT** submerge the end of hose into water; otherwise it can cause an air lock in the hose.
- To avoid water spillage:
  - As the negative pressure of condensate drain pan is large, tilt the drain hose downward toward the floor. It is appropriate that the degree of inclination should exceed 20 degrees.
  - Straighten the hose to avoid a trap existing in the hose.

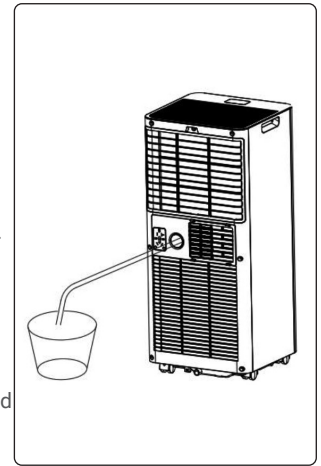

## Maintenance

- **CLEANING: THE AIR FILTER** (every 2 weeks)
- Dust collects on the filter and restricts the airflow. The restricted airflow reduces the efficiency of the system and if it becomes blocked it can cause damage to the unit.
- The air filter requires regular cleaning. The air filter is removable for easy cleaning. Do not operate the unit without an air filter, or the evaporator may be contaminated.
- 1. Press **POWER** button to switch off the unit and unplug the power cord.
- 2. Remove the filter mesh from the unit.
- 3. Use a vacuum cleaner to suck dust from the filter.
- 4. Turn the filter over and rinse the air filter under running water. Let the water run through the filter in the opposite direction of air flow. Set aside and allow the filter to air dry completely before reinstalling.
- **DO NOT** touch the evaporator surface with bare-hands to avoid injury.

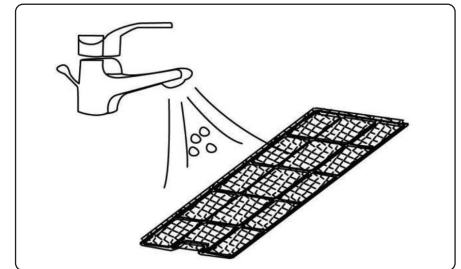

## Troubleshooting

Symptoms		Cause	Solution
The unit is not operating.		Check the mains connection.	Insert the mains plug correctly.
		Check if the water level indicator lights up?	Empty the drain pan.
		Check the room temperature.	The range of operating temperature is 5-35°C.
The unit works with reduced capacity.		Check the air filter for dirt.	Clean the air filter as necessary.
		Check if the air duct is blocked.	Clear the obstacle.
		Check if the room door or window is open.	Keep the door and windows closed.
		Check if the desired operating mode is selected and the temperature is properly set.	Set the mode and temperature at proper set-point according the manual.
		The exhaust hose is detached.	Make sure the exhaust hose is securely attached.
Water leakage.		Overflow whilst moving the unit.	Empty the water tank before moving.
		Check if the drain hose is kinked or bends.	Straighten the hose to avoid a trap existing.
Excessive noise.		Check if the unit is securely positioned.	Place the unit on horizontal and firm ground.
		Noise sounds like water flowing.	Noise comes from flowing refrigerant. This is normal.
		Check if any loose, vibrating parts.	Investigate and secure.
Error codes	E0	Communication faults between main PCB and display PCB.	Check the wire harness of the display PCB for damage.
	E1	Ambient temperature sensor failure.	Check connection or replace it. To clean or replace the temperature sensor.
	E2	Coil temperature sensor failure.	Check connection or replace it. To clean or replace the temperature sensor.
	Ft	Condensate water high level alarm.	Empty drain pan by removing drain bung.

## Storage

- Long-Term Storage - If you will not be using the unit for an extended period of time (more than a few weeks) it is best to clean the unit and dry it out completely. Please store the unit per the following steps:
- Unplug the unit and remove exhaust hose and window kit store with the unit.
- Drain the remaining water from the unit.
- Clean the filter and let the filter dry completely in a shaded area.
- Re-install the filter at its position.
- The unit must be kept in upright position when in storage.
- Store in a ventilated, dry, safe place indoors.
- **ATTENTION:**
- The evaporator inside the machine has to be dried out before the unit is stored to avoid component damage and mold.
- Unplug the unit and place it in a dry open area for several days to dry it out. Another way to dry the unit is turn on the machine, adjust it to low-wind ventilation mode, and maintain this state until the drainage pipe becomes dry, so as to keep the inside of the body in a dry state and prevent it from mildewing.

---

# WINDOW SEALING KIT FOR AIR CONDITIONER DUCTING

## MODEL NO: SACWK1

## Safety

- **DO NOT** cover the unit with this material, and do not obstruct the air inlet and outlet grilles of the machine with items such as clothing, soft furnishings, furniture, bedding etc.
- **DO NOT** use the material for any purpose other than that for which it is designed.
- **DO NOT** use in bathroom or shower room.
- **DO NOT** allow children to use.
- When not in use, store in a safe, cool, dry, childproof area.

## Contents

- Window seal
- Velcro tape



## Instructions

- **CLEANING**
- Clean the window and window frame of grease and dust.
- **CUTTING THE VELCRO TAPE TO SIZE**
- Cut the Velcro tape to size, using a pair of scissors. Mark the middle (M) of the window seal (Fig. 1). Mark the middle of the window frame and the casement (Fig. 2-4) (Figure 2 shows an open window, Figure 3 a tilted window and Figure 4 an open skylight).
- **VELCRO TAPE TO THE WINDOW FRAME**
- Adhere the Velcro tape to the window frame around the window. Then adhere the Velcro tape fully around the window. Stick the Velcro tape to the front side (in most cases 1cm wide) of the casement or to the inner surface of the casement (where the window handle is attached).
- **CAUTION: DO NOT** adhere the Velcro tape on the window.
- **SEALING WINDOW TO WINDOW FRAME**
- Adhere the narrow side of the window seal to the Velcro tape on the window frame. Work from the centre and fully adhere the narrow side all the way around. First fasten side A, then side B, starting in the middle and working all the way to the left and right. **IMPORTANT!** When fastening, point A must be exactly opposite point B.
- **SEALING THE WINDOW**
- Leave the window ajar and adhere the wide side of the window seal to the Velcro tape of the window.
- **CAUTION:** Leave sufficient space, so that the window seal will not get jammed.
- **OPENING THE WINDOW SEAL**
- Open the zip of the window seal approximately 50 cm. Open the zip preferably at the positions marked with "S" and attach the exhaust air hose.
- **ATTACHING THE AIR DISCHARGE**
- Insert the air discharge hose of the air conditioning system through the hole in the window seal and close the zip until the air discharge hose is properly secured
- **CLOSING THE WINDOW**
- If you want to close your window, simply detach the cloth from the Velcro tape. When closing the window take care that the seal is not jammed between the casement and window frame.
- **NOTE:** This window seal ensures that the room remains cool for a longer period of time and keeps insects and mosquitoes out.

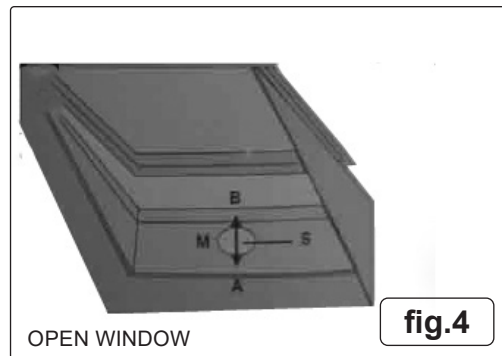
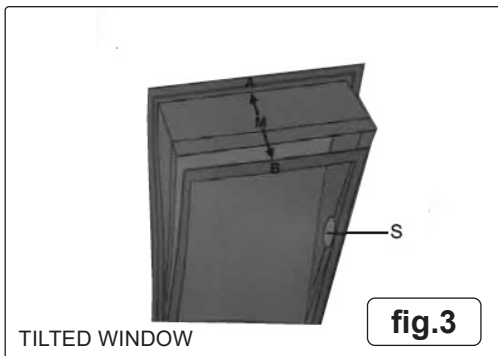
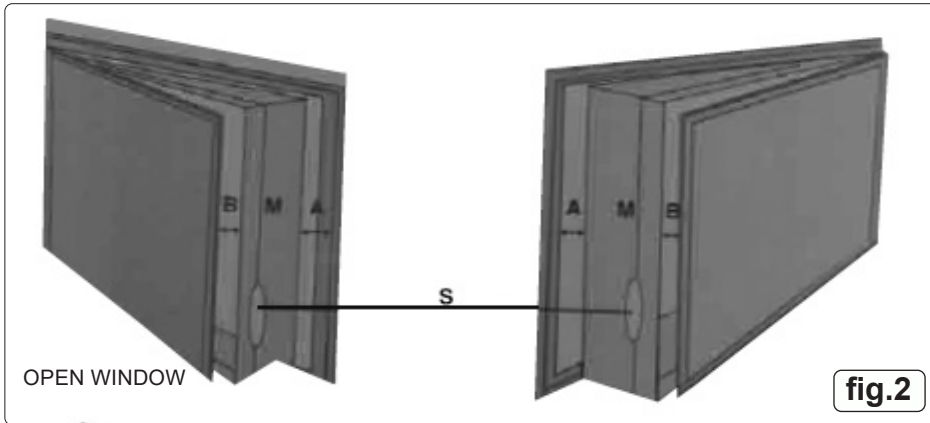
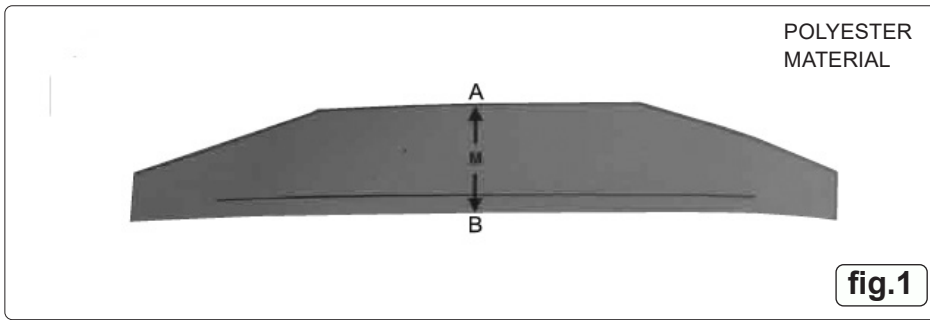

• The installed item will resemble fig.5 and fig.6.

## Wifi

- The "Smart Life" app is available for android and iOS.
- Scan the corresponding QR code to get directly to the download.
- **INFORMATION ON HOW TO USE THE APP**
- This appliance allows you to operate the appliance via your home network. A prerequisite is a permanent **WIFI** connection to your router and the free app "Smart Life."
- 1. Install the "Smart Life" app. Create a user account.
- 2. Activate the **WIFI** function in the settings of your appliance.
- 3. Place the appliance at a distance of about 5 meters from your router.
- 4. Long press the "Timer" button to start the network configuration, when the **WIFI** indicator flashes, you can connect the **WIFI**. After 3 minutes, the status will be cancelled if there is no network configuration, and the indicator light is off.
- If you need to re-connect the **WIFI**, long press the "Timer" button to start the network configuration again, the **WIFI** indicator will flash again.
- **WIFI CONNECTION**
- **METHOD 1**
- Connect via Bluetooth



Download Smart Life App



- Open the bluetooth of your mobile phone or other device .When **WIFI** indicator flashes,open“ Smart Life”**APP**,the unit will connect via bluetooth automatically.
- **METHOD 2**
- When **WIFI** indicator flashes, select “Add Device” - “Large Home Appliances” - “ Portable Air Conditioner”, and follow the instructions on the display.
- Check the status of the **WIFI** indicator and choose the correct status.
- If the **WIFI** indicator flashes rapidly, it can connect directly.
- If the **WIFI** indicator flashes slowly, press “Go to Connect” to connect the **WIFI** named “SmartLife-XXXX”, then back to the **APP**, the **WIFI** will connect ok.
- **REMARKS:**
- Once the appliance has been successfully connected, the **WIFI** lamp lights up. Now you can operate the appliance using the app.
- Press and hold the Timer button for about 5 seconds, the appliance disconnects, the **WIFI** lamp light is off.
- WiFi and Bluetooth main technical parameters
- Frequency range (WiFi): 2400-2483.5MHz; RF power≤20dBm (EIRP)
- Frequency range(BLE):2400-2483.5MHz; RF power≤20dBm (EIRP)

## End of life

- At the end of its useful life unit must be recycled according to regulations in force.

### Product Information Sheet. Air Conditioners.

SUPPLIER\_NAME\_OR\_TRADEMARK Dellonda EU Ltd.  
 DELEGATED\_ACT 206/2012/EU  
 MODEL\_IDENTIFIER DH412  
 4-in-1 Portable Air Conditioning Unit with Window Sealing Kit 5,000Btu/hr - White

ADDRESS Farney Street, Carrickmacross, Co. Monaghan, A81 PK68 Ireland  
 PHONE\_NUMBER 01284 757 500  
 EMAIL\_ADDRESS TechnicalCompliance@dellonda.co.uk

Parameter	Verification tolerances
Rated Capacity for cooling kW	1.5
Rated capacity for heating kW	NA
Power input for cooling kW	NA
Power input for heating kW	NA
Rated Energy efficiency ratio	2.6
Rated coefficient of performance	NA
Power consumption in thermostat-off mode W	NA
Power consumption in standby mode W	2.0
Electricity consumption of single duct appliances kWh/h Cooling	0.6
Electricity consumption of single duct appliances kWh/h Heating	NA
Electricity consumption of double duct appliances kWh/a Cooling	NA
Electricity consumption of double duct appliances kWh/a Heating	NA
Sound power level LWA dB	65
Global warming potential GWP kg	0

Suppliers website <https://www.sealey.co.uk/>

### Environment Protection and Waste Protection and Electrical Equipment Regulations (WEEE)

Recycle unwanted packaging materials. When this product is no longer required, or has reached the end of it's useful life, please dispose of it in an environmentally friendly way. Drain any fluids (if applicable) into approved containers, in accordance with local waste regulations. Under the It is our policy to continually improve products and we reserve the right to alter data, specifications and parts without prior notice. No liability is accepted for incorrect use of this product. Guarantee is 12 months from purchase date, proof of which is required for any claim.

**Jack Sealey Ltd t/a Baridi**, Kempson Way, Suffolk Business Park, Bury St Edmunds, Suffolk, IP32 7AR UK  
**Jack Sealey (EU) Ltd t/a Baridi**, Farney Street, Carrickmacross, Co. Monaghan, A81 PK68 Ireland  
 Tel: 01284 757575 • Email: support@baridi.co.uk • Web: www.baridi.co.uk